

剖面 A-A

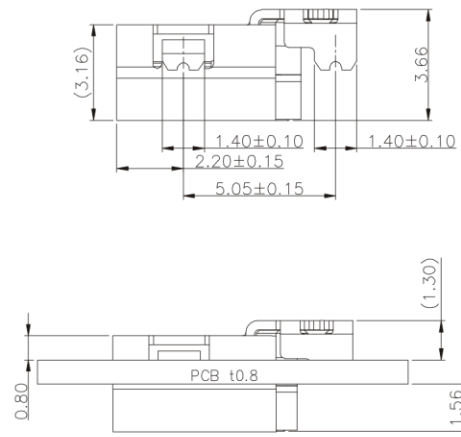

MOUNTING CONDITION (REF.)

NOTES : (UNLESS OTHERWISE SPECIFIED)

MATERIAL

- ① MOLDING : THERMOPLASTIC-LCP, UL94V-0
- ② CONTACT : COPPER ALLOY, SELECTIVE GOLD PLATING
- ③ SHELL : SUS304-H, T=0.30mm±0.03mm, NICKEL PLATED
- ④ SHIELD : SUS304-H, T=0.12mm±0.03mm

SPECIFICATION

- ① VOLTAGE RATING : 20V AC RMS
- ② CURRENT RATING : 5 AMPHERES MIN. FOR VBUS; 0.25 AMPERE MIN. FOR OTHERS.
- ③ CONTACT RESISTANCE : 40mΩ MAX.
- ④ INSULATION RESISTANCE : 100MΩ MIN.
- ⑤ WITHSTAND VOLTAGE : 100V AC.
- ⑥ MATING/UNMATING FORCE : 5~20N.
- ⑦ DURABILITY : 10,000 MATING CYCLES MIN.
- ⑧ OPERATING TEMPERATURE : -55°C ~ +85°C

ORDER OPTIONS

RUC04-1 \* \* R024C4

- PLATING
  - 0~Au 0.2~1μ ON CONTACT AREA
  - 1~Au 3μ ON CONTACT AREA
  - 4~Au 15μ ON CONTACT AREA
  - 6~Au 30μ ON CONTACT AREA
- HOUSING COLOR
  - 1~BLACK
  - 2~BEIGE
  - A~BLUE

RoHS <small>Directive compliance 2002/95/EC</small> 	<b>METRIC</b>	<b>Han Electronic</b>
	DRAWN	
	APPROVER	TITLE
	DIMENSIONS ARE IN MILLIMETERS TOLERANCES X.X        ±0.38 X.XX      ±0.25 X.XXX     ±0.10 ANGULAR   ±3°	RUC04-1**R024C4 PRODUCT NO.
THIRD ANGLE PROJECTION	SIZE <b>A4</b>	SHEET NO. 1 OF 2
	SCALE	1 : 1

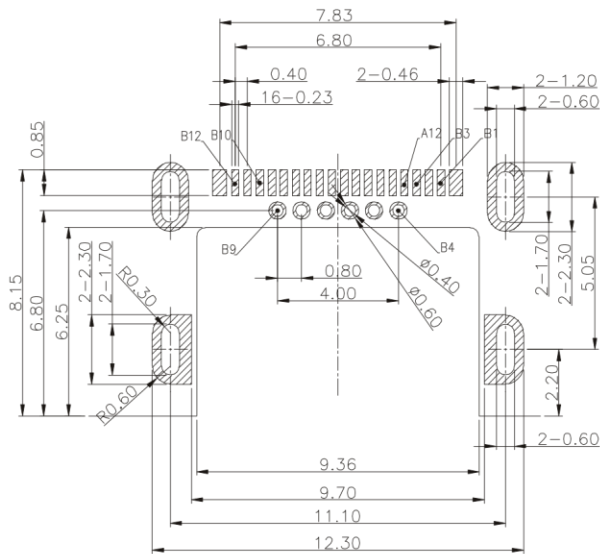
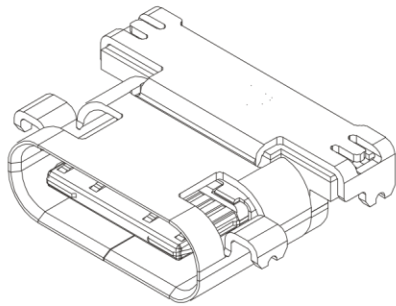

**RECOMMEND P.C.B LAYOUT (COMPONENT SIDE)**

TOLERANCE FOR PCB LAYOUT IS ± 0.05

KEEP OUT AREA

USB TYPE-C FULL-FEATURED RECEPTACLE INTERFACE PIN ASSIGNMENTS

PIN	Signal Name	Description	PIN	Signal Name	Description
A1	GND	Ground return	B12	GND	Ground return
A2	SSTXp1	Positive half of first SuperSpeed TX differential pair	B11	SSRXp1	Positive half of first SuperSpeed RX differential pair
A3	SSTXn1	Negative half of first SuperSpeed TX differential pair	B10	SSRXn1	Negative half of first SuperSpeed RX differential pair
A4	VBUS	Bus Power	B9	VBUS	Bus Power
A5	CC1	Configuration Channel	B8	SBU2	Sideband Use (SBU)
A6	Dp1	Positive half of the USB 2.0 differential pair-Position 1	B7	Dn2	Negative half of the USB 2.0 differential pair-Position 2
A7	Dn1	Negative half of the USB 2.0 differential pair-Position 1	B6	Dp2	Positive half of the USB 2.0 differential pair-Position 2
A8	SBU1	Sideband Use (SBU)	B5	CC2	Configuraation Channel
A9	Vbus	Bus Power	B4	VBUS	Bus Power
A10	SSRXn2	Negative half of second SuperSpeed RX differential pair	B3	SSTXn2	Negative half of second SuperSpeed TX differential pair
A11	SSRXp2	Positive half of second SuperSpeed RX differential pair	B2	SSTXp2	Positive half of second SuperSpeed TX differential pair
A12	GND	Ground return	B1	GND	Ground return

RoHS Directive compliant 2002/95/EC 	<b>METRIC</b> DRAWN: _____ APPROVER: _____		<b>Han Electronic</b>
	DIMENSIONS ARE IN MILLIMETERS TOLERANCES X.X ±0.38 X.XX ±0.25 X.XXX ±0.10 ANGULAR ±3°		
			PRODUCT NO. <b>RUC04-1**R024C4</b>
	SIZE <b>A4</b>	SHEET NO. <b>2 OF 2</b>	SCALE <b>1 : 1</b>